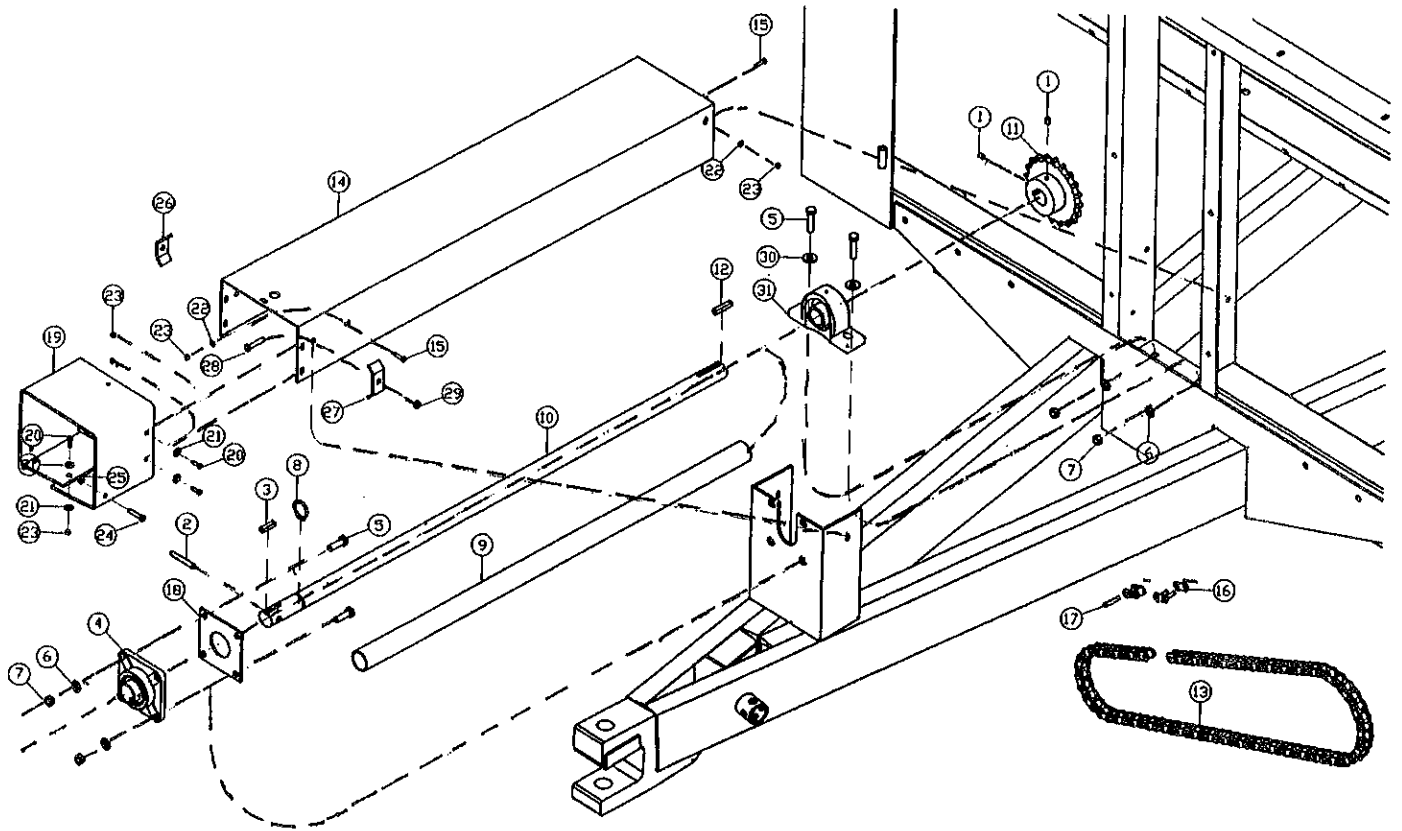

**FIGURE 1  
CHASSIS & AXLE ASSEMBLIES**

ITEM	P/N	DESCRIPTION	ITEM	P/N	DESCRIPTION
1.	50N150	Main Frame	29.	60N8	Hub
2.	50N151	LH Tandem Beam	30.	60N10	Outer Race - 600 BU
3.	50N152	RH Tandem Beam	31.	60N9	Outer Bearing - 600 BU
4.	50N153	Tandem Pin	32.	60N11	Hub Cap - 600 BU
5.	RG174	Bolt 5/8" x 5" GR.5	33.	60N12	Hub Cap Bolt - 600 BU
6.	RG8	5/8" Flat Washer	34.	60N13	Stud - 600 BU
7.	T69	Lock Washer 5/8"	35.	60N14	Stud Nut - 600 BU
8.	T68	Nut 5/8"	36.	RG59	Spacer
9.	50N5	Spindle 3" x 25-5/8" (500 BU)	37.	16SV89	Wheel (22-1/2 x 13-1/2 - 8 Bolt)
10.	B4	Spindle Washer	38.	60N15	Wheel (22-1/2 x 13-1/2 - 10 Bolt)
11.	T35	Spindle Nut	39.	50N6	Wheel (16.1 x 18 - 8 Bolt)
12.	33SV46	Spindle Cotter Key	40.	60N16	Wheel (16.1x18 - 10 Bolt)
13.	33SV42	Seal	41.	16SV88	Tire (425 x 22.5 - Truck)
14.	33SV43	Inner Bearing	42.	50N7	Tire (21.51 x 16.1 - Flotation)
15.	33SV44	Inner Race	43.	50N8	Bushing
16.	33SV45	Hub	44.	50N9	5000# x 15" Jack
17.	RG169	Outer Race	45.	12N12	Jack Handle
18.	RG170	Outer Bearing	46.	12N13	Jack Pin & Chain
19.	RG171	Hub Cap	47.	12N9	Replacement Gears (NOT SHOWN)
20.	33SV41	Stud	48.	50N10	Bolt 1/2" x 5" GR.2
21.	RG72	Stud Nut	49.	R35	Lock Washer 1/2"
22.	60N1	Spindle 3" x 27-5/8" (600 BU)	50.	R29	Nut 1/2"
23.	60N2	Spindle Washer	51.	50N98	Mount Reinforcement Plate
24.	60N3	Spindle Nut	52.	16SV50	Bolt 3/4" x 2-1/2" GR.5
25.	60N4	Cotter Key	53.	HE7	Lock Nut 3/4"
26.	60N5	Seal	54.	RG135	Bolt 1/2" x 1" GR.5
27.	60N7	Inner Bearing	55.	R10	Carriage Bolt 1/2" x 1" GR.5
28.	60N6	Inner Race	56.	BFR439	Bolt 5/8" x 1-3/4" GR.5



**FIGURE 2  
SHIELD & INPUT ASSEMBLY**

ITEM	P/N	DESCRIPTION	ITEM	P/N	DESCRIPTION
1.	---	PTO Set Screw	18.	50N167	Front Bearing Mount
2.	12V59	PTO Roll Pin	19.	50N163	PTO Rubber
3.	16SV90	PTO Key 3/8" x 1-1/2"	20.	K83	Bolt 1/4" x 3/4" GR.2
4.	12V67	Input Shaft Bearing	21.	T16	Flat Washer 1/4"
5.	50N11	Bolt 1/2" x 1-1/2" GR.2	22.	K84	Lock Washer 1/4"
6.	R35	Lock Washer 1/2"	23.	LW140	Nut 1/4"
7.	R29	Nut 1/2"	24.	16SV192	Shear Bolt 5/16" x 1" GR.5 (1000 RPM)
8.	12V62	Snap Ring	---	16SV191	Shear Bolt 3/8" x 1" GR.8 (540 RPM)
9.	50N155	Shield	25.	16SV194	Shear Nut 5/16"
10.	50N154	Input Shaft	---	16SV193	Shear Nut 3/8"
11.	12V104	Sprocket 20T	26.	23N67	Hose Bracket, RH
12.	PB87	Key 3/8" x 2" Sq.	27.	HE42	Hose Bracket, LH
13.	50N156	#80 Chain - 123 Pitch	28.	BFR320	Bolt 3/8" x 1-3/4" GR.2
14.	50N149	Input Shaft Shield	29.	K93	Lock Nut 3/8"
15.	D110	Bolt 1/4" x 1" GR.2	30.	K68	Flat Washer 1/2"
16.	F157	#80 Chain Connector	31.	16SV72	Front Shaft Bearing
17.	F158	#80 Chain Offset			

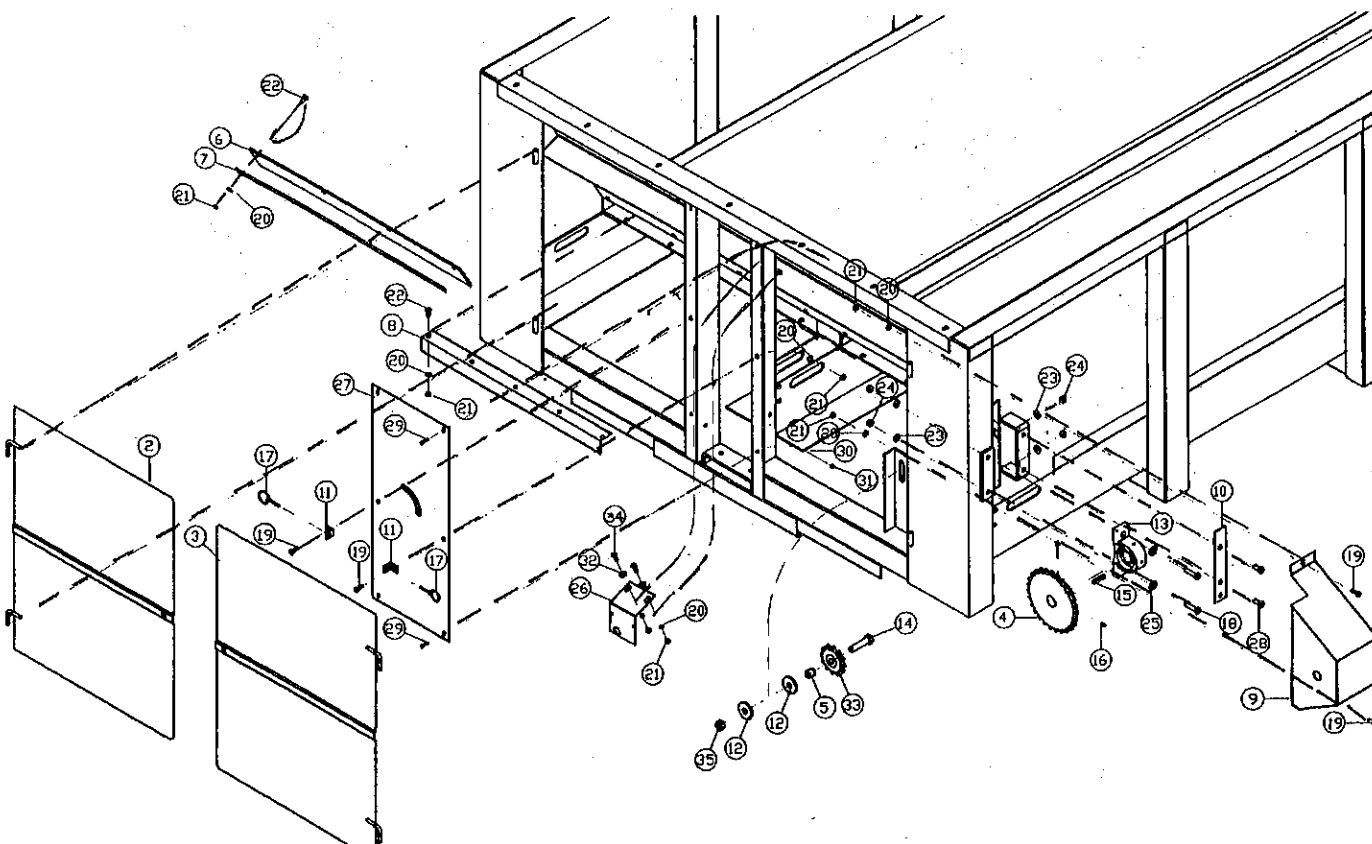

**FIGURE 3  
FRONT ASSEMBLY**

ITEM	P/N	DESCRIPTION	ITEM	P/N	DESCRIPTION
1.	50N145	Tub	19.	A15	Bolt 3/8" x 1" GR.2
2.	50N143	RH Front Shield	20.	B68	Lock Washer 3/8"
3.	50N144	LH Front Shield	21.	K60	Nut 3/8"
4.	50N45	Sprocket 27T	22.	BFR247	Carriage Bolt 3/8" x 1" GR.5
5.	50N162	Side Tightener Spacer	23.	R35	Lock Washer 1/2"
6.	50N50	Front Panel Rubber	24.	R29	Nut 1/2"
7.	50N51	Front Panel Strap	25.	K68	Flat Washer 1/2"
8.	50N52	Front Floor Brace	26.	16SV331	Flow Control Mount
9.	50N141	Side Sprocket Shield	27.	50N159	Control Panel
10.	50N158	Side Shield Bracket	28.	RG75	Bolt 1/2" x 1" GR.2
11.	F92	Front Shield Mount	29.	D110	Bolt 1/4" x 1" GR.2
12.	16SV211	Tightener Washer	30.	K84	Lock Washer 1/4"
13.	16SV72	Front Jackshaft Bracket	31.	LW140	Nut 1/4"
14.	18N48	Bolt 3/4" x 3" Bolt GR.5	32.	K135	Flat Washer 3/8"
15.	PB87	3/8" x 2" Sq. Key	33.	12V77	Tightener Sprocket
16.	---	3/8" Set Screw	34.	A15	Bolt 3/8" x 1" GR.2
17.	F56	Linchpin	35.	HE7	Lock Nut 3/4"
18.	F52	Bolt 1/2" x 2" GR.5			

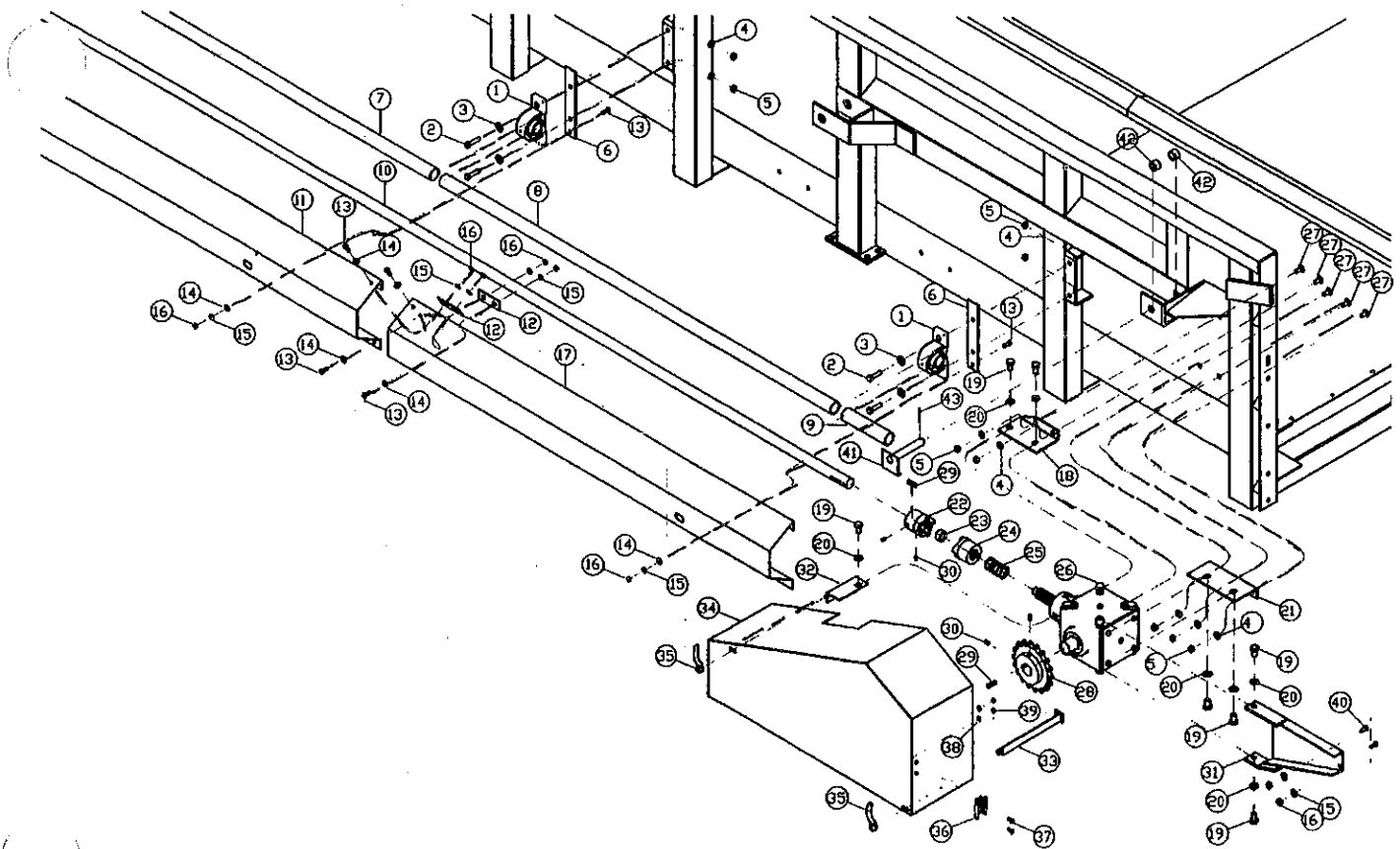

**FIGURE 4  
SIDE SHIELDS & DRIVE ASSEMBLIES**

ITEM	P/N	DESCRIPTION	ITEM	P/N	DESCRIPTION
1.	16SV72	Side Shaft Bearing	21.	50N105	Bottom Gearbox Mount
2.	F52	Bolt 1/2" x 2" GR.5	22.	16SV69	Keyed Clutch
3.	K68	Flat Washer 1/2"	23.	16SV70	Bushing 1-1/2" OD x 1" ID x 3/4"
4.	R35	Lock Washer 1/2"	24.	16SV71	Spine Clutch
5.	R29	Nut 1/2"	25.	43NW17	Clutch Spring
6.	50N158	Shield Bracket	26.	50N96	Complete Gearbox
7.	50N101	Shaft Guard 1-1/2" PVC x 94-3/8"	27.	50N82	Carriage Bolt 1/2" x 1" GR.5
8.	50N102	Shaft Guard 1-1/2" PVC x 76-1/8"	28.	50N107	Sprocket 18T
9.	50N103	Shaft Guard 1-1/2" PVC x 8-1/4"	29.	16SV90	3/8" x 1-1/2" Sq. Key
10.	50N166	Side Shaft	30.	---	3/8"-16 Set Screw
11.	50N156	Side Shield Front	31.	50N106	Gearbox Brace
12.	50N110	Side Shield Splice Tab	32.	50N112	Gearbox Shield Front Mount
13.	A15	Bolt 3/8" x 1" GR.5	33.	50N113	Gearbox Shield Rear Mount
14.	X67	Flat Washer 3/8"	34.	50N111	Gearbox Shield
15.	B68	Lock Washer 3/8"	35.	S192	Gearbox Shield Fastener
16.	K60	Nut 3/8"	36.	F97	SMV Bracket
17.	50N157	Side Shield Rear	37.	50N116	Carriage Bolx 5/16" x 3/4" GR.2
18.	50N104	Top Gearbox Mount	38.	RGB39	Lock Washer 5/16"
19.	50N115	Bolt 5/8" x 1" GR.5	39.	T116	Nut 5/16"
20.	T69	Lock Washer 5/8"	40.	BFR247	Carriage Bolt 3/8" x 1" GR.2

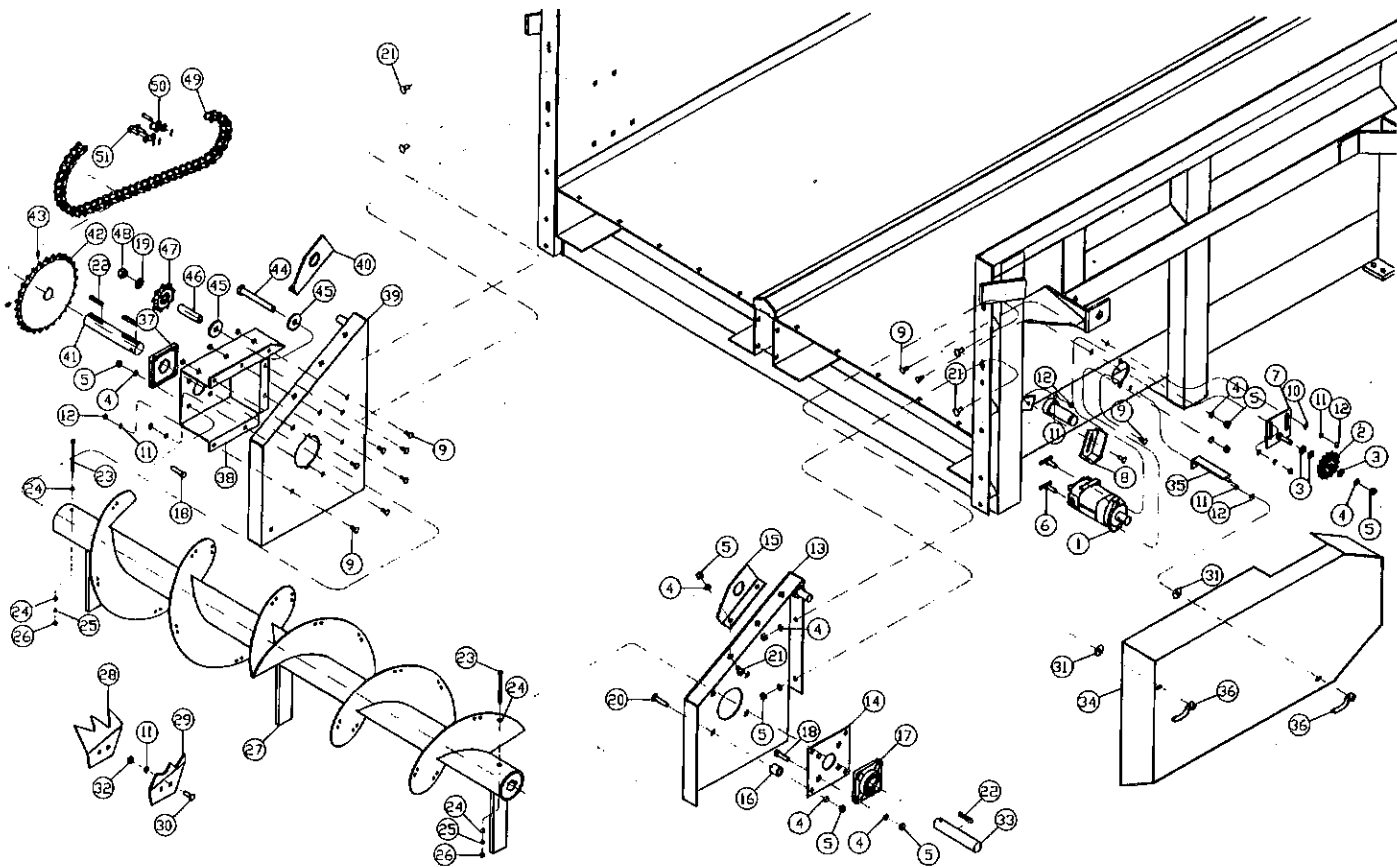

**FIGURE 5  
BEATER & BEATER DRIVE ASSEMBLIES**

ITEM	P/N	DESCRIPTION	ITEM	P/N	DESCRIPTION
1.	16SV150	Hydraulic Motor	27.	50N122	Beater
2.	12N42	Sprocket 15T	28.	50N117	LH Beater Blade
3.	K68	Flat Washer 1/2"	29.	50N118	RH Beater Blade
4.	R35	Lock Washer 1/2"	30.	R10	Beater Blade Bolt 1/2" x 1-1/4" GR.5 (Special)
5.	R29	Nut 1/2"	31.	K135	Flat Washer 3/8"
6.	50N77	Hydraulic Motor Fastener	32.	R11	Top Lock Nut 1/2"
7.	50N71	Hydraulic Motor Tightener Bracket	33.	50N123	RH Beater Shaft
8.	50N75	Apron Drive Tightener	34.	50N72	Apron Shield
9.	BFR247	Carriage Bolt 3/8" x 1" GR.5	35.	50N73	Front Apron Shield Mount
10.	X67	Flat Washer 3/8"	36.	S192	Shield Handle Nut
11.	R35	Lock Washer 1/2"	37.	50N58	LH Beater Bearing
12.	K60	Nut 3/8"	38.	50N126	LH Beater Bearing Support
13.	50N125	RH Beater Panel	39.	50N124	LH Beater Panel
14.	50N26	RH Beater Bearing Support	40.	50N127	LH Beater Lifting Eyelet
15.	50N128	RH Beater Lifting Eyelet	41.	50N121	LH Beater Drive Shaft
16.	50N27	Bearing Support Spacer	42.	50N120	Sprocket 28T
17.	50N29	RH Beater Bearing	43.	---	3/8" Set Screw
18.	50N11	Bolt 1/2" x 1-1/2" GR.5	44.	50N129	Bolt 3/4" x 6" GR.5
19.	16SV49	Washer	45.	16SV211	Beater Tightener Washer
20.	50N32	Carriage Bolt 1/2" x 2" GR.5	46.	50N119	Beater Tightener Spacer
21.	50N82	Carriage Bolt 1/2" x 1" GR.5	47.	33SV30	Sprocket 9T
22.	S38	3/8" x 2-3/8" Sq. Key	48.	HE7	Lock Nut 3/4"
23.	23N1	Bolt 5/16" x 5" GR.5	49.	50N130	Beater Chain #100 60 Pitch
24.	---	Flat Washer 5/16"	50.	33SV76	#100 Chain Offset
25.	RGB39	Lock Washer 5/16"	51.	33SV77	#100 Chain Connector
26.	D81	Nut 5/16"			

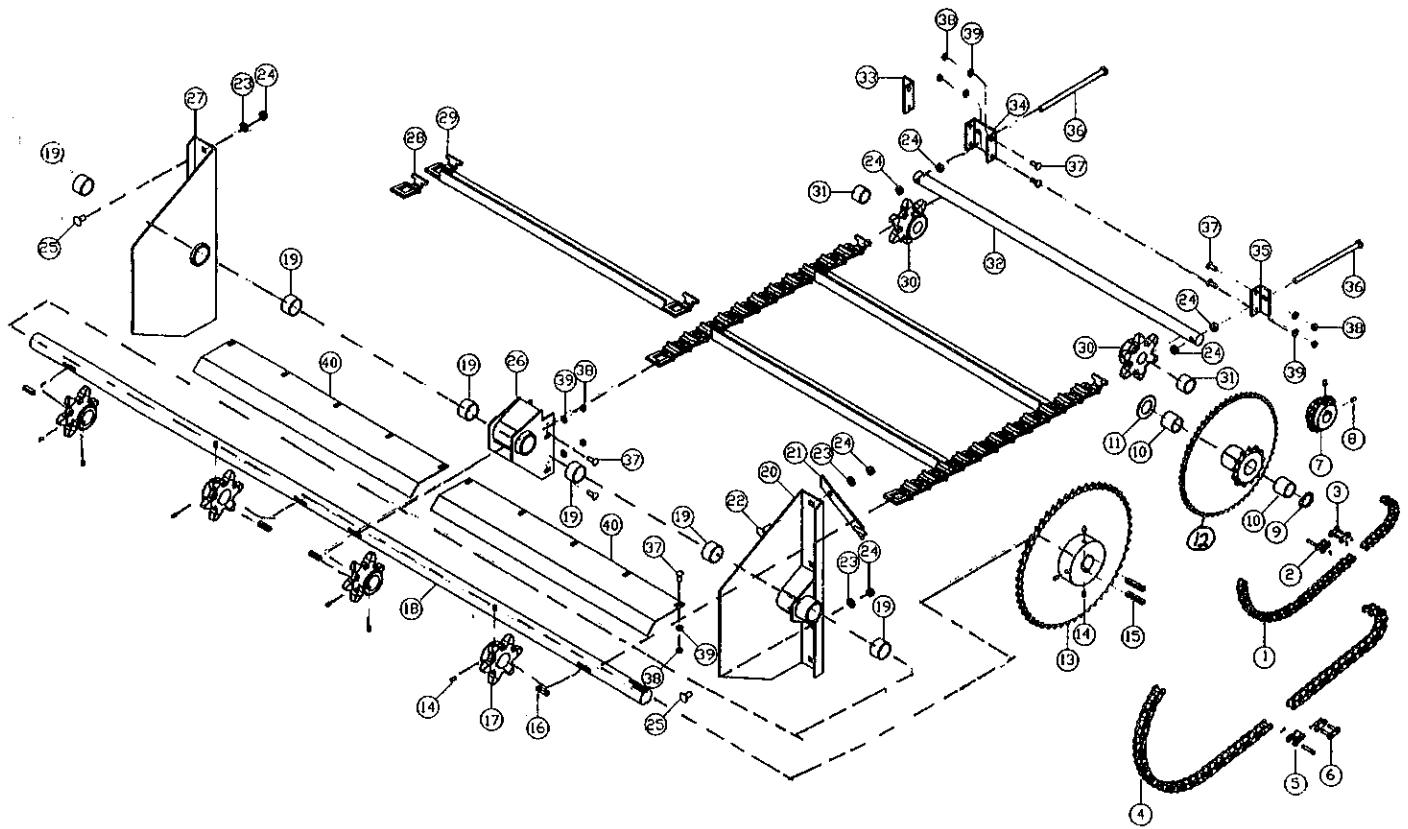

**FIGURE 6  
APRON CHAIN & DRIVE ASSEMBLIES**

ITEM	P/N	DESCRIPTION	ITEM	P/N	DESCRIPTION
1.	50N79	#60 Chain 78 Pitches	21.	50N74	Rear Apron Shield Mount
2.	D38	#60 Chain Offset	22.	50N81	Carriage Bolt 1/2" x 1-1/2" GR.5
3.	D39	#60 Chain Connector	23.	R35	Lock Washer 1/2"
4.	50N80	#80 Chain 69 Pitches	24.	R29	Nut 1/2"
5.	F158	#80 Chain Offset	25.	50N82	Carriage Bolt 1/2" x 1" GR. 5
6.	F157	#80 Chain Connector	26.	50N62	Center Apron Bearing Bracket
7.	16SV31	Sprocket 16T	27.	50N146	LH Apron Shaft Bracket
8.	---	5/16" Setscrew	28.	A12	67 T-Bar Link - 284
9.	12V62	Snap Ring	29.	50N57	67 T-Bar Slat - 28
10.	17G134	Bushing 1-3/4" OD x 1-1/2" ID x 1-1/2"	30.	JB10	6T Apron Sprocket
11.	50N76	Reduction Sprocket Spacer	31.	50N67	Apron Idler Shaft Spacer
12.	50N69	Reduction Sprocket	32.	50N68	Apron Idler Shaft
13.	50N70	Sprocket 52T	33.	50N64	LH Apron Tightener Bracket
14.	---	3/8" Setscrew	34.	50N66	Center Apron Tightener Bracket
15.	S38	3/8" x 2-3/8" Sq. Key	35.	50N65	RH Apron Tightener Bracket
16.	16SV90	3/8" x 1-1/2" Sq. Key	36.	A7	Bolt 1/2" x 9-1/2" GR.5 Full Thread
17.	S37	Apron Drive Sprocket	37.	BFR247	Carriage Bolt 3/8" x 1" GR.5
18.	50N63	Apron Drive Shaft	38.	K60	Nut 3/8"
19.	S50	Bushing 2" OD x 1-3/4" ID x 1-1/8"	39.	B68	Lock Washer 3/8"
20.	50N147	RH Apron Shaft Bracket	40.	50N83	Rear Apron Brace

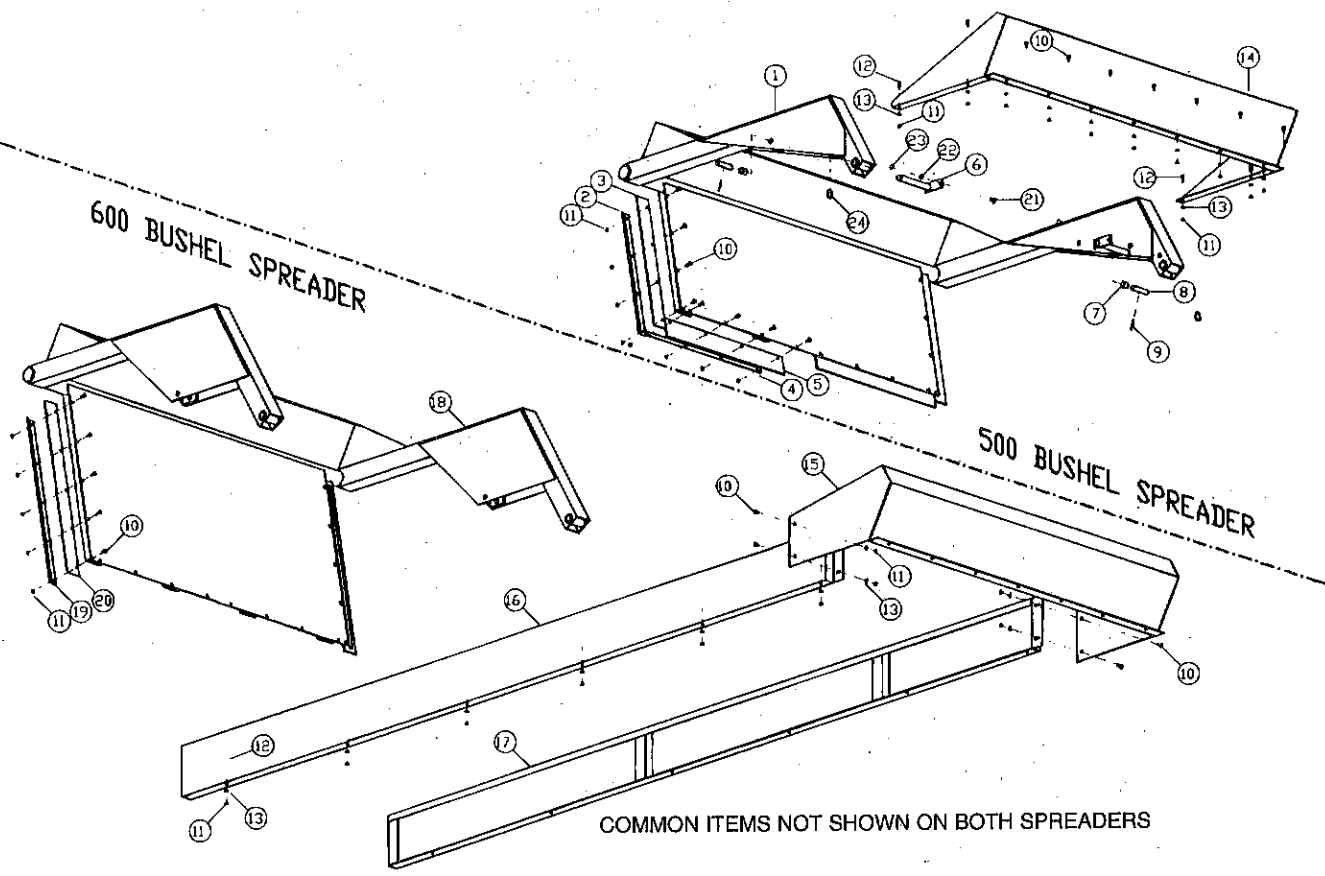
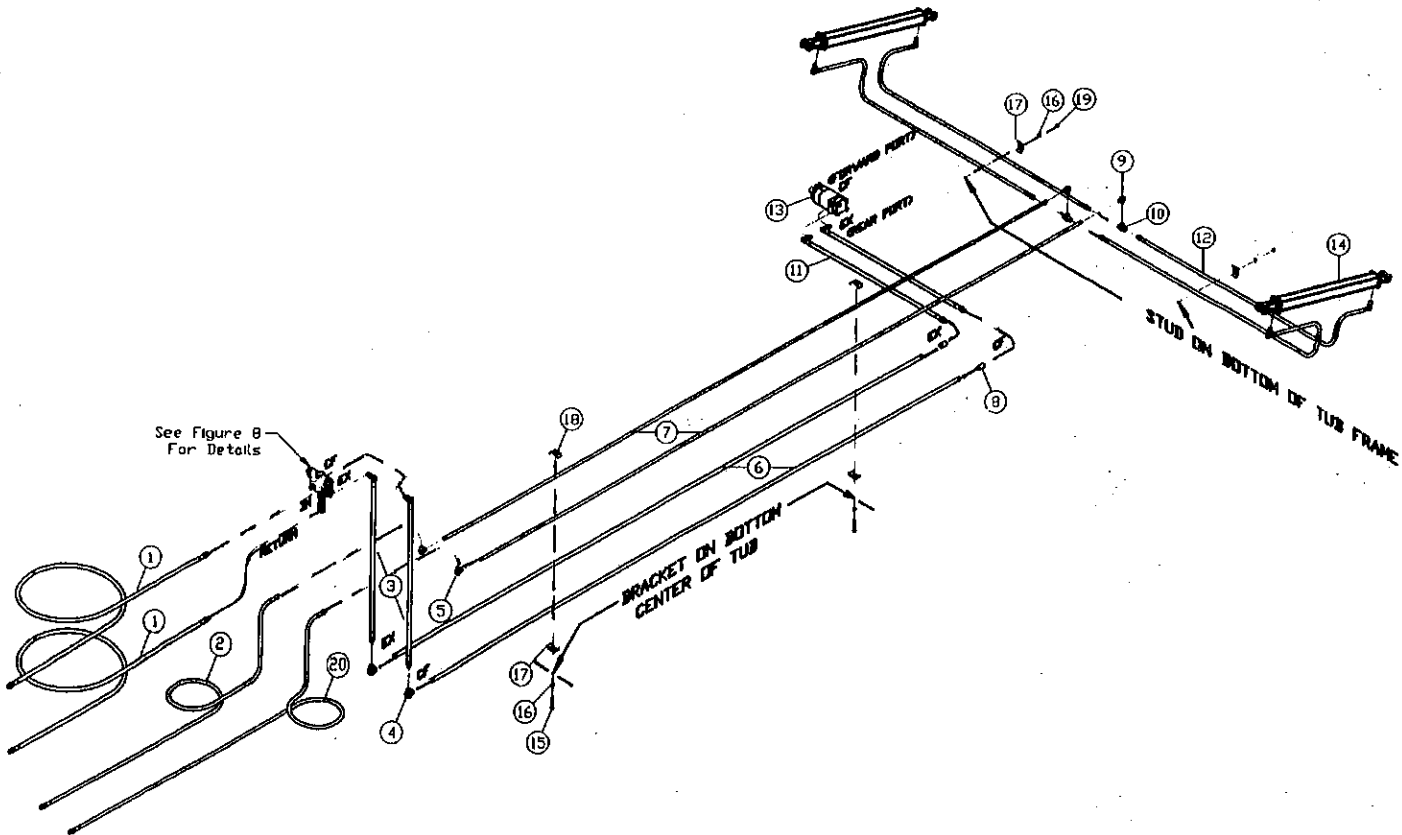

**FIGURE 7  
ENDGATES, FRONT SPLASHES & SIDE EXTENSIONS**

ITEM	P/N	DESCRIPTION	ITEM	P/N	DESCRIPTION
1.	50N84	Endgate - 500 Bushel	13.	B68	Lock Washer 3/8"
2.	50N85	Endgate Side Strap	14.	50N91	Front Splash - 500 BU
3.	50N86	Endgate Side Rubber	15.	60N20	Front Splash - 600 BU
4.	50N87	Endgate Bottom Strap	16.	60N22	RH Side Extension - 600 BU
5.	50N88	Endgate Bottom Rubber	17.	60N21	LH Side Extension - 600 BU
6.	50N142	Endgate Pivot Pin	18.	60N17	Endgate - 600 BU
7.	50N138	Rod End Cylinder Spacer	19.	60N18	Endgate Side Strap - 600 BU
8.	50N90	Endgate Rod End Pin	20.	60N19	Endgate Side Rubber - 600 BU
9.	T56	5/32" x 2" Cotter Pin	21.	50N82	Carriage Bolt 1/2" x 1" GR.5
10.	BFR247	Carriage Bolt 3/8" x 1" GR. 5	22.	R35	Lock Washer 1/2"
11.	K60	Nut 3/8"	23.	R29	Nut 1/2"
12.	A15	Bolt 3/8" x 1"	24.	F73	External Snap Ring 1-1/4"

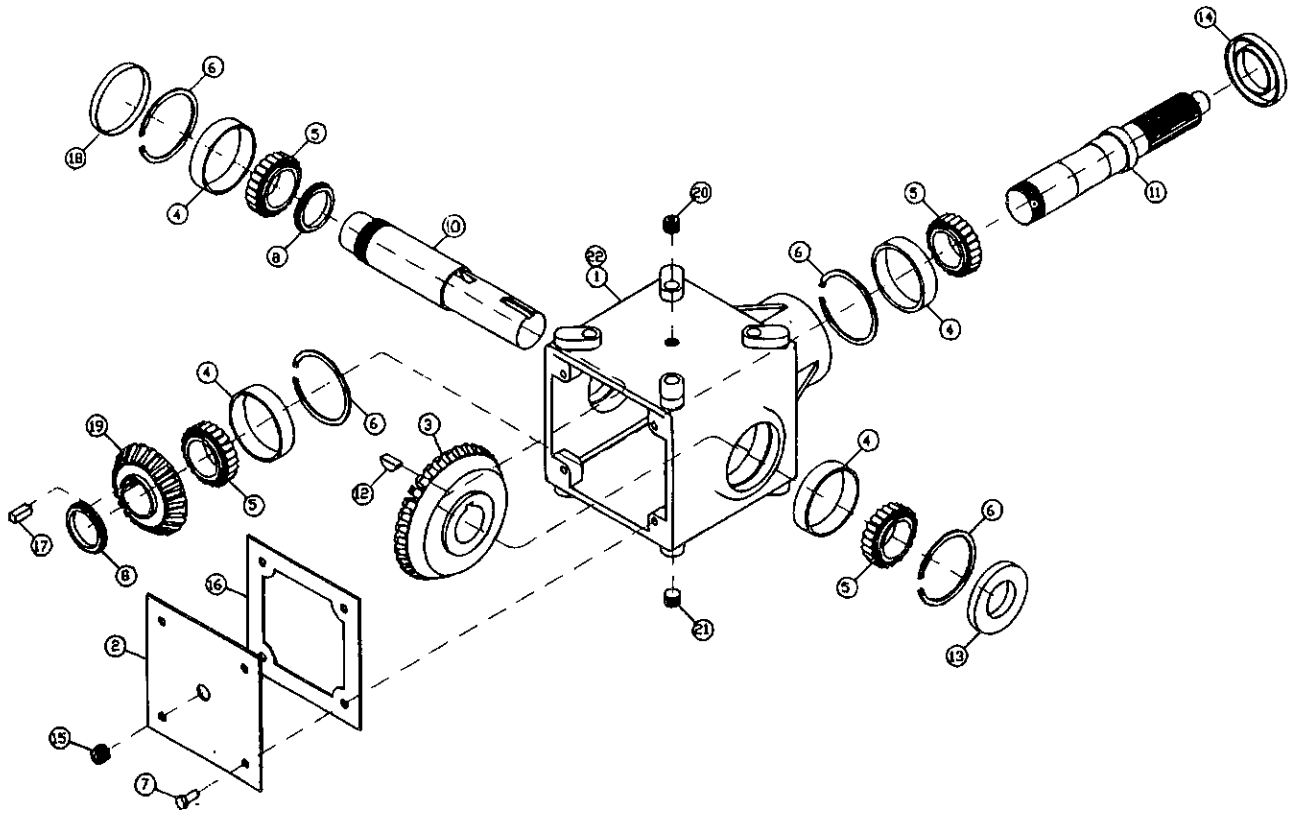





**FIGURE 9  
HYDRAULICS ASSEMBLY**

ITEM	P/N	DESCRIPTION	ITEM	P/N	DESCRIPTION
1.	50N17	Apron Hose	11.	50N134	Hydraulic Motor Hose
2.	16SV140	Short Endgate Hose	12.	23N113	Hydraulic Cylinder Hose
3.	50N18	Flow Control Hose	13.	16SV150	Hydraulic Motor
4.	50N135	1/2" Female Elbow	14.	50N92	Hydraulic Cylinder
5.	HE59	3/8" Female Elbow	15.	43H5	Bolt 3/8" x 3" GR.2
6.	50N160	Motor Hydraulic Line	16.	B68	Lock Washer 3/8"
7.	50N161	Endgate Hydraulic Line	17.	23N67	Hydraulic Line Holder
8.	PB105	1/2" Coupling	18.	50N137	Hydraulic Line Holder
9.	23N234	3/8" Street Elbow	19.	K60	Nut 3/8"
10.	BFR74	3/8" Female Tee	20.	50N164	Long Endgate Hose



**FIGURE 10  
GEARBOX ASSEMBLY**

ITEM	P/N	DESCRIPTION	ITEM	P/N	DESCRIPTION
1.	G125	Housing	12.	G61	Woodruff Key
2.	G126	Cover	13.	G136	Seal, Output
3.	G127	Bevel Gear, 33 Tooth	14.	G137	Seal, Input
4.	G128	Bearing Cup	15.	G65	Plug 3/8" NPT
5.	G129	Bearing Cone	16.	G138	Gasket
6.	G130	Snap Ring	17.	50N140	3/8" x 1" Sq. Key
7.	G131	Cap Screw	18.	G140	Cap
8.	G132	Stake Nut	19.	G142	Bevel Gear, 22 Tooth
9.	G133	Stake Nut	20.	G144	Vent Plug
10.	50N99	Shaft, Output	21.	G145	Plug
11.	G135	Shaft, Input	22.	50N96	Gearbox, Complete

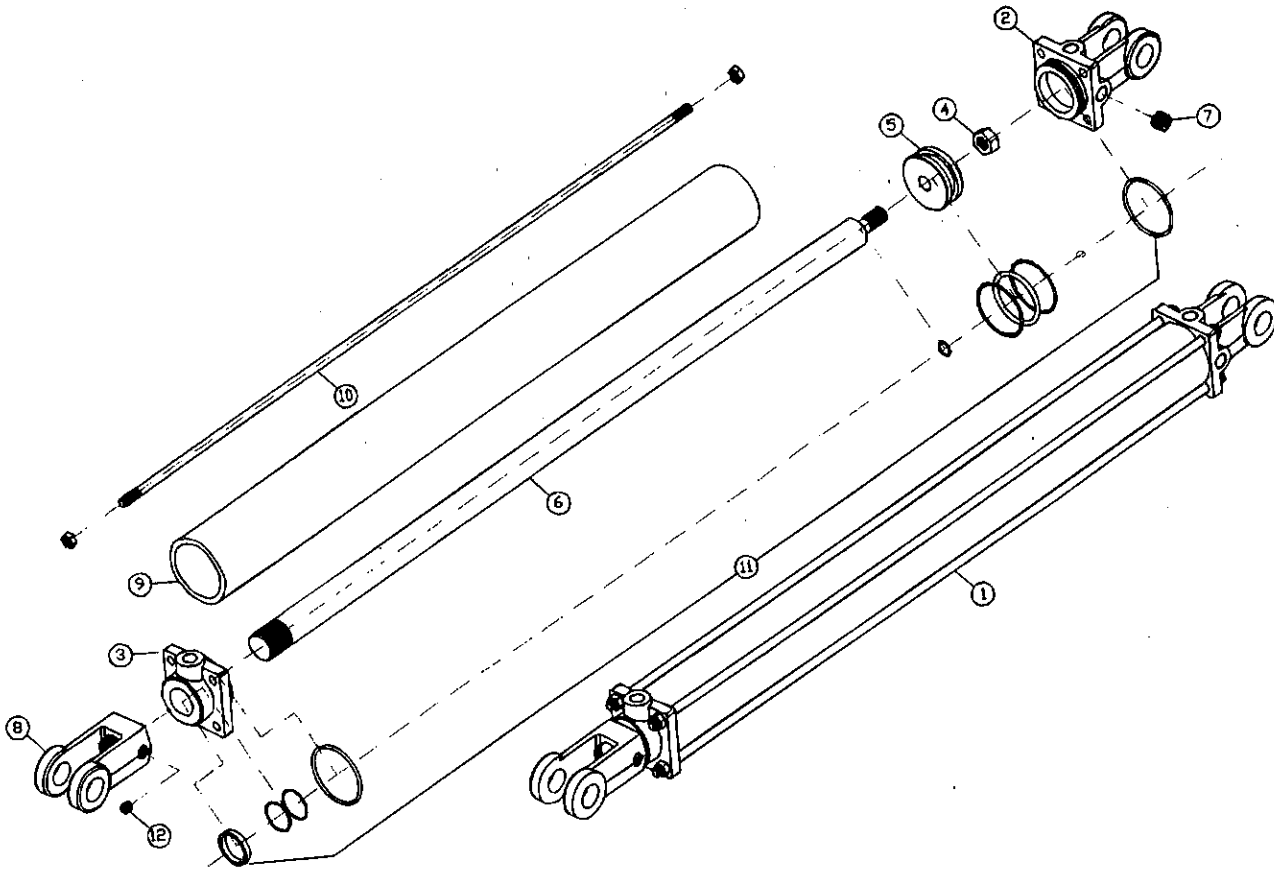

**FIGURE 11  
HYDRAULIC CYLINDER ASSEMBLY**

ITEM	P/N	DESCRIPTION	ITEM	P/N	DESCRIPTION
1.	50N92	Complete Cylinder	7.	23N149	Plug
2.	T181	Clevis Cap	8.	23N150	Rod Clevis
3.	T182	Rod Cap	9.	50N94	Cylinder Tube
4.	23N148	Piston Nut	10.	50N95	Tie Rod
5.	T183	Piston	11.	T187	Seal Kit
6.	50N93	Rod	12.	---	Setscrew

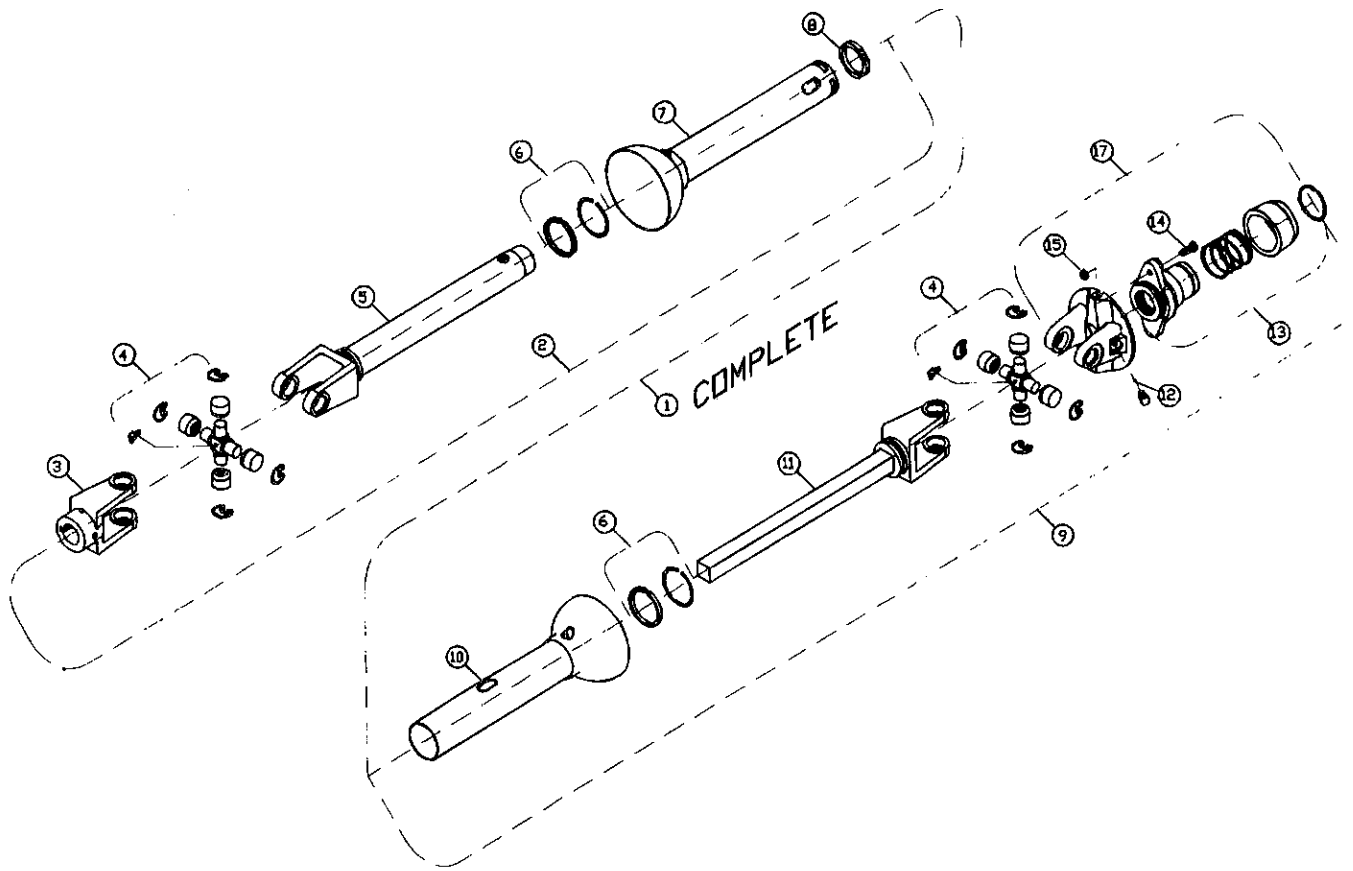

**FIGURE 12  
PTO ASSEMBLIES**

ITEM	540 RPM	1000 RPM - 1-3/8"	1000 RPM - 1-3/4"	DESCRIPTION
1.	16SV172	16SV173	16SV174	Complete PTO
2.	16SV175	"	"	Joint & Tube Half w/Guard
3.	16SV178	"	"	End Yoke
4.	16SV179	"	"	Repair Kit (U-Joint)
5.	16SV180	"	"	Yoke & Tube Assembly
6.	16SV181	"	"	Guard Retainer Repair Kit
7.	16SV182	"	"	Inner Guard
8.	4A27	"	"	Nylon Centralizer
9.	16SV183	16SV184	16SV185	Joint & Shaft Half w/Guard
10.	16SV186	"	"	Outer Guard
11.	16SV187	"	"	Yoke & Shaft Assembly
12.	16SV188	"	"	Ball Shear Repair Kit (31 )
13.	16SV189	"	16SV190	Safety Slide Lock Repair Kit
14.	16SV191	16SV192	"	Bolt, Shear
15.	16SV193	16SV194	"	Lock Nut, Top
16.	16SV195	16SV196	16SV197	Ball Shear Assembly
17.	16SV198	16SV199	16SV200	Complete Ball Shear Assembly

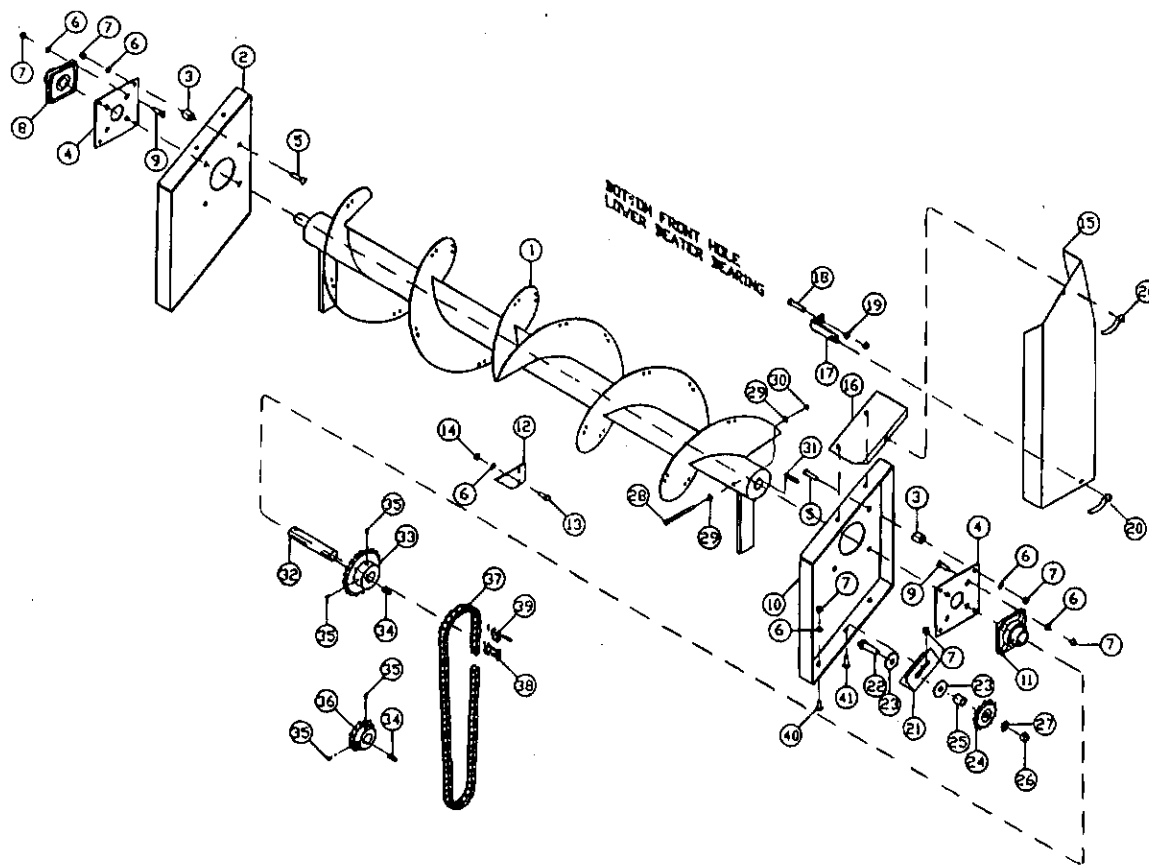

**FIGURE 13**  
**2ND BEATER (OPTIONAL ON MODEL 500)**

ITEM	P/N	DESCRIPTION	ITEM	P/N	DESCRIPTION
1.	50N19	2nd Beater	25.	16SV44	Sprocket Spacer
2.	50N20	2nd Beater LH Panel	26.	HE7	Lock Nut 3/4"
3.	50N27	Bearing Support Spacer	27.	T73	Tightener Washer
4.	50N26	Beater Support	28.	23N1	Bolt 5/16" x 5" GR.5
5.	50N32	Carriage Bolt 1/2" x 2" GR.5	29.	---	Flat Washer 5/16"
6.	R35	Lock Washer 1/2"	30.	D81	Nut 5/16"
7.	R29	Nut 1/2"	31.	S38	Beater Plug Key 3/8" Sq.
8.	50N30	LH Beater Bearing	32.	50N28	RH Drive Shaft
9.	50N11	Bolt 1/2" x 1-1/2" GR.5	33.	12V104	Beater Sprocket 20T
10.	50N21	2nd Beater RH Panel	34.	A32	3/8" x 1-3/8" Sq. Key
11.	50N29	RH Beater Bearing	35.	---	Sprocket Set Screw
12.	16SV93	Beater Pin	36.	ST11	Sprocket 13T
13.	R10	Bolt 1/2" x 1-1/4" GR.5 (Special)	37.	50N31	#80 Chain 70 Pitch
14.	R11	Lock Nut 1/2"	38.	F157	#80 Chain Connector
15.	50N22	Beater Chain Shield	39.	F158	#80 Chain Off Set
16.	50N23	Top Shield Mount	40.	50N81	Carriage Bolt 1/2" x 1-1/2" GR.5
17.	50N24	Shield Mount	41.	50N32	Carriage Bolt 1/2" x 2" GR.5
18.	17G98	Carriage Bolt 1/2" x 2-1/2" GR.5			
19.	K68	Flat Washer 1/2"			
20.	S192	Shield Handle Nut			
21.	50N25	Tightener Bracket			
22.	16SV50	Bolt 3/4" x 2-1/2" GR.5			
23.	16SV211	Washer			
24.	12V77	Sprocket 12T			
**	12V52	Sprocket Bearing			

\*\* - NOT SHOWN